

## ❖ **Bảng thông số quy đổi góc mở của ống kính .**

- Khi chúng ta thiết kế một hệ thống camera giám sát, việc chọn ống kính rất quan trọng. Việc chọn ống kính quyết định đến vùng và khoảng cách cần quan sát. Sau đây chúng tôi xin giới thiệu tới các bạn bảng thông số quy đổi để xác định được diện tích của vùng quan sát (góc mở của ống kính) .

Kích thước cảm biến	Ống kính	Góc quan sát ngang	Góc quan sát dọc	Góc quan sát chéo
1/4" CCD	2.8mm	65°28'	51°28'	77°34'
	3.5mm	54°25'	42°11'	65°28'
	4mm	48°27'	37°17'	58°42'
	4.8mm	41°06'	31°25'	50°13'
	6mm	33°23'	25°21'	41°06'
	8mm	25°21'	19°09'	31°25'
	12.5mm	16°23'	12°19'	20°24'
	16mm	12°50'	9°38'	16°00'
	17mm	12°05'	9°04'	15°04'
	25mm	8°14'	6°10'	10°17'
	35mm	5°53'	4°25'	7°21'
	50mm	4°07'	3°05'	5°09'
	75mm	2°44'	2°03'	3°26'
	8.5-51mm	23°54' ~ 4°02'	18°02' ~ 3°01'	29°39' ~ 5°03'
	12.5-75mm	16°23' ~ 2°44'	12°19' ~ 2°03'	20°24' ~ 3°26'
	11-110mm	18°35' ~ 1°52'	13°59' ~ 1°24'	23°07' ~ 2°20'
16-160mm	12°50' ~ 1°17'	9°38' ~ 0°58'	16°00' ~ 1°36'	
1/3" CCD	2.8mm	81°12'	65°28'	93°56'
	3.5mm	68°52'	54°25'	81°12'
	4mm	61°55'	48°27'	73°44'
	4.8mm	53°07'	41°06'	64°00'
	6mm	43°36'	33°23'	53°07'
	8mm	33°23'	25°21'	41°06'
	12.5mm	21°44'	16°23'	26°59'
	16mm	17°03'	12°50'	21°14'
	17mm	16°04'	12°05'	20°00'
	25mm	10°58'	8°14'	13°41'
	35mm	7°50'	5°53'	9°47'
	50mm	5°29'	4°07'	6°52'
	75mm	3°39'	2°44'	4°34'
	8.5-51mm	31°32' ~ 5°23'	23°54' ~ 4°02'	38°52' ~ 6°43'
	12.5-75mm	21°44' ~ 3°39'	16°23' ~ 2°44'	26°59' ~ 4°34'
	11-110mm	24°36' ~ 2°29'	18°35' ~ 1°52'	30°30' ~ 3°07'
16-160mm	17°03' ~ 1°43'	12°50' ~ 1°17'	21°14' ~ 2°08'	

1/2" CCD	2.8mm	97°37'	81°12'	110°00'
	3.5mm	84°52'	68°52'	97°37'
	4mm	77°19'	61°55'	90°00'
	4.8mm	67°22'	53°07'	79°36'
	6mm	56°08'	43°36'	67°22'
	8mm	43°36'	33°23'	53°07'
	12.5mm	28°43'	21°44'	35°29'
	16mm	22°37'	17°03'	28°04'
	17mm	21°19'	16°04'	26°28'
	25mm	14°35'	10°58'	18°10'
	35mm	10°26'	7°50'	13°02'
	50mm	7°19'	5°29'	9°08'
	75mm	4°53'	3°39'	6°06'
	8.5-51mm	41°15' ~ 7°10'	31°32' ~ 5°23'	50°24' ~ 8°58'
	12.5-75mm	28°43' ~ 4°53'	21°44' ~ 3°39'	35°29' ~ 6°06'
11-110mm	32°26' ~ 3°19'	24°36' ~ 2°29'	39°57' ~ 4°09'	
16-160mm	22°37' ~ 2°17'	17°03' ~ 1°43'	28°04' ~ 2°51'	

## ❖ Tìm hiểu về ống kính của camera giám sát .

### Image format size :

There are presently four main image format sizes, which are commonly used in CCTV cameras: 1", 2/3", 1/2", 1/3" (these measures refers to the sensor diagonal).

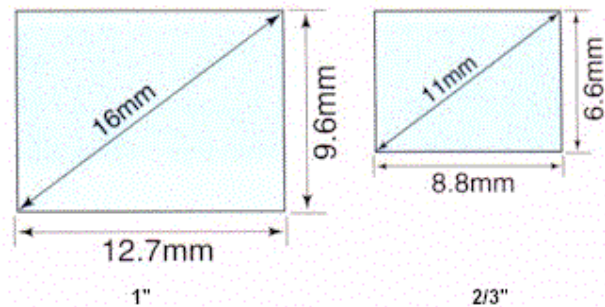

Moreover, 1/4" and 1/5" format sizes have been introduced recently in the market.

A lens designed for a specific image format can always be used with a smaller format imaging device, but cannot be used with a larger format imaging device.

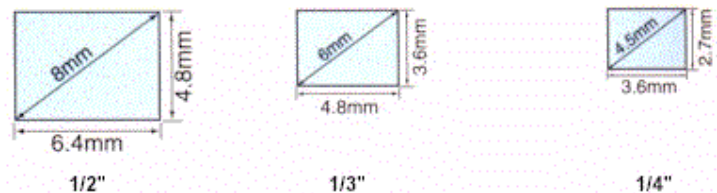

: A 1/2" format lens can be used with a camera having a 1/2" or a 1/3" imager; however it cannot be used with 2/3" or 1" format cameras.

**Focal length :**

The rays from an infinitely distant object are concentrated by the lens at a common point of the optical axis, which is called *focal point*.

A lens has two focal points: the primary and the secondary principal point.

The distance from the secondary point to the focal point on the optical axis (where the imager is placed) is the *focal length* of the lens.

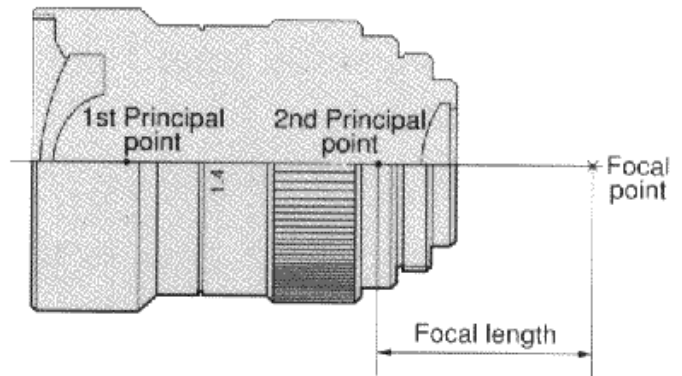

**Angle of view :**

The angle of view of a lens depends both on the focal length and on the sensor format size. The larger is the format size, the larger is the angle of view for a given focal length.

**Aperture ratio :**

It is the ratio between the effective diameter and the focal length of the lens and shows the actual brightness of the lens itself; it is specified by the F-No. The smaller is the F-No, the brighter is the lens.

: A lens specified with f1.3 is brighter than another one having f1.8.

**Formula:**  $F=f/A$  F=F number (brightness)  
 f=focal length  
 A=aperture=effective diameter

**Angle field of view :**

It is the angle defined by two rays of light crossing at the secondary focal point.

It depends from the focal length and from the imager format size.

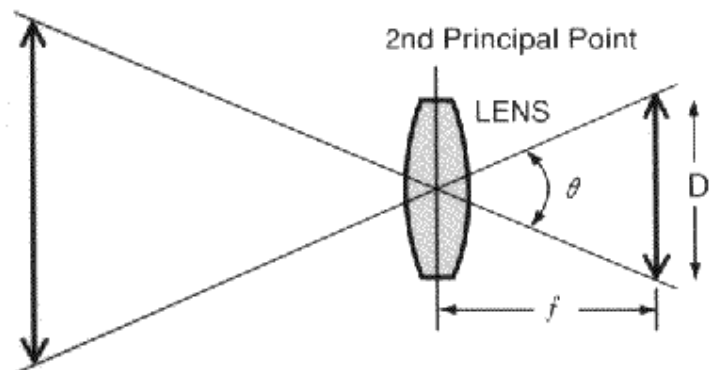

**Formula:**  $w=2 \times \tan^{-1} D/2f$  D=object dimension  
 f=focal length

**Back focal length :**

It is the distance between the last element of a lens group and the focal point.

**Flange back length :**

It is the distance from the flange surface (contact point between camera and lens) and the focal length and is always fixed, depending on mount type.

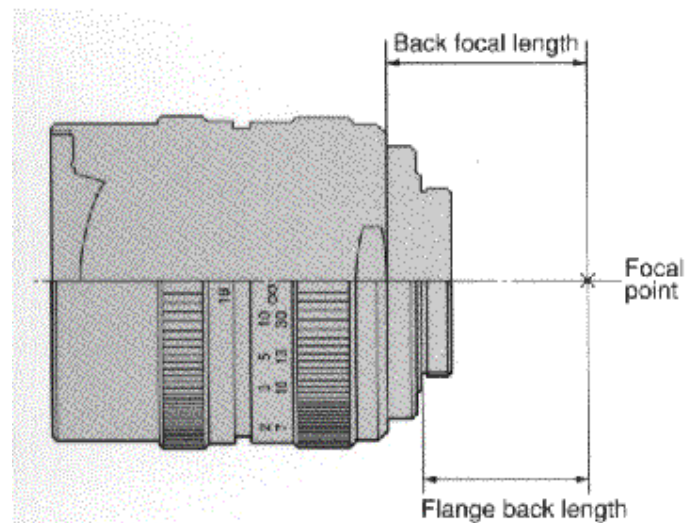

**C mount and CS mount :**

These are the two standard mounts for CCTV cameras. The only difference between them is the flange back length C=17,256mm CS=12,5mm. C mount lenses can also be used on cameras having CS mount standard, by using C/CS ring adaptors. CS mount lenses can only be used with cameras having CS mount standard.

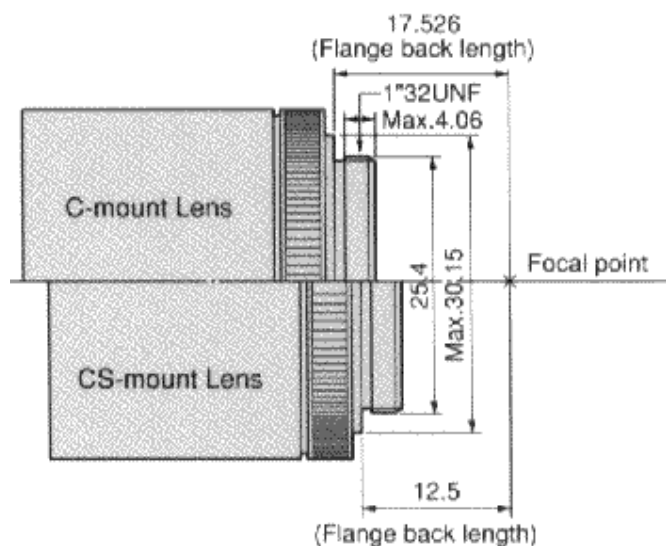

**Close-up focusing :**

When the object to be viewed is at a smaller distance than the minimum focusing distance of the lens, the rays of lights will be focusing on a point beyond the imager surface; therefore the image is not focused. To focus the image two methods can be used:

**a) Extension tube set**

These are rings which are inserted between lens and camera. Lens is thus positioned at a larger distance from the camera, bringing the object nearer. In this way the point where the rays of light are focused is shifted towards the sensor surface. However the depth of field is reduced, therefore only objects at a certain distance can be focused properly. By changing the object distance, the thickness of the extension tube is also to be changed. Extension tube sets are not recommended in case of using zoom lenses.

**b) Close-up lenses**

These are additional lenses, applied on the front of lenses themselves, to correct the convergence of rays of light and thus to reduce the minimum focusing distance. They are fitted in front of the lens. The close-up lenses have a given strength which is measured in **dioptr**, defined as the reciprocal of the focusing distance (in meters).

A close-up lens with a strength of +4 diopters, will always focus an object at a distance of 25 cm (1/4 m), regardless of the focal length of the lens.

Formula:  $D=1/d$  D=diopters  
d=focusing distance (in meters)

**Depth of field :**

Is the range of distance from an optical system where the image of an object is always focused.

The depth of field is:

- a) inversely proportional to the **focal length**.
- b) inversely proportional to the **aperture ratio** (f number).

Consequently:

- a) wider angle lenses have larger depth of field ; eventually, the image remains always focused at the lower focal lengths. This is the reason why in most wide angle lenses there is not the focusing ring, but the iris ring only.
- b) by closing the iris the depth of field increases. For this reason, the iris setting should be made when the iris is completely open (lower light), with the higher aperture ratio (for instance at night). Object focused in this light condition, will be focused also with a more closed iris position (higher light intensity).